



AFTER



BEFORE

GAME Streetmekka Viborg

Streetmekka is a renovation project that transformed an abandoned windmill factory into a vibrant hub for street sports and street culture, offering various facilities for self-organized sports and social spaces for the local youth of Viborg in Denmark.

Located in the outskirts of Viborg, the original building was a typical example of the mass-produced warehouses from the 70's found in many suburban industrial areas of the world.

Despite the generic appearance, these typologies often contain an impressive interior space and the idea was to open up the introverted building and expose it to the outside world. By removing the walls at both ends of the building and placing all the office and workshop spaces on one side and the skating on the other, the interiors are kept as free as possible. The existing concrete facade is wrapped in a new translucent skin that gives the appearance of a light and welcoming building, changing from day to night.

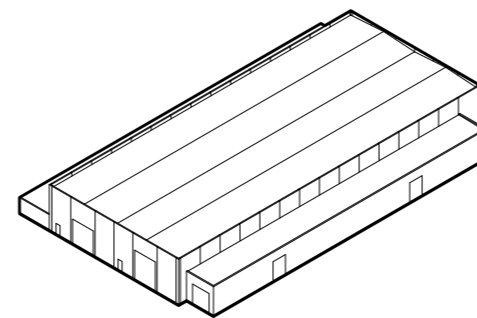

existing building

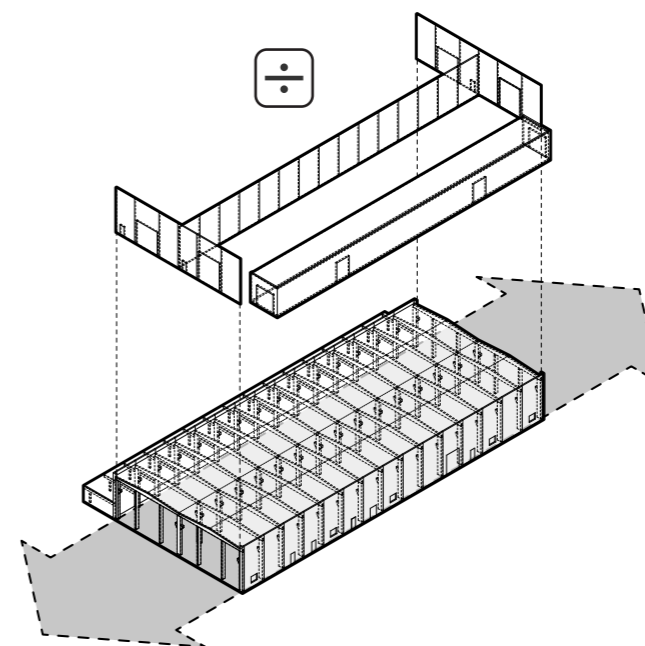

removing and opening up

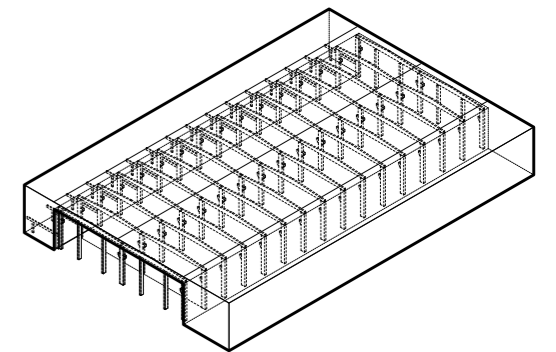

adding new on